

EVGA X58 SLI LE VISUAL GUIDE

The following quick steps will guide you through testing the absolute bare minimum essentials of your motherboard before installing it into a system chassis. Visual aids are provided to assist you during the following procedures.

To reduce the risk of fire, electric shock, and injury always follow basic safety precautions. It is recommended that you use electrostatic discharge (ESD) countermeasures such as an ESD wrist strap or anti-static mat when handling computer components. After removing the EVGA X58 SLI LE from its packaging, place it on to a nonconductive surface. For example: wood, cardboard box, or an anti-static mat.

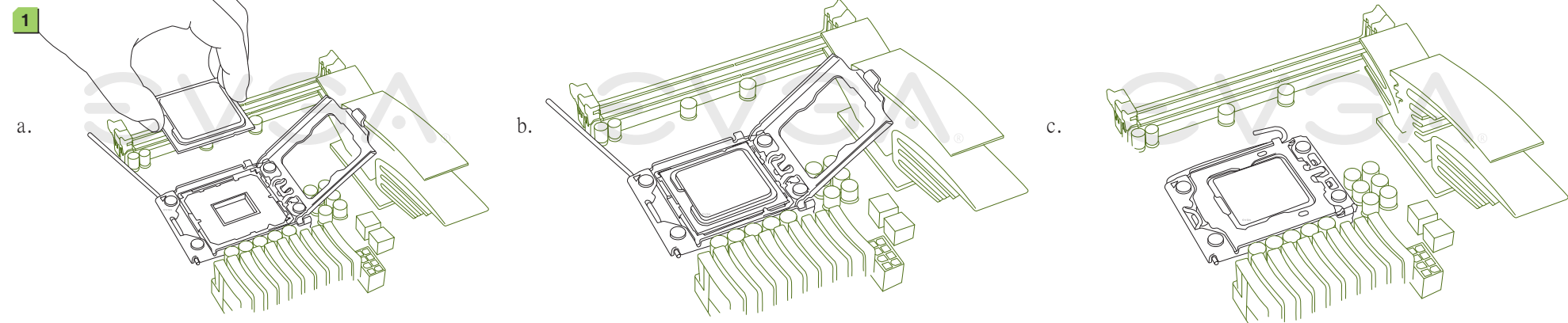

1. Unhook the socket lever and lift up the load plate. Remove the 1366 protective cover and carefully install your Intel processor making sure to properly align the notches. Close the load plate and with light pressure, lower the socket lever back in to its original position.

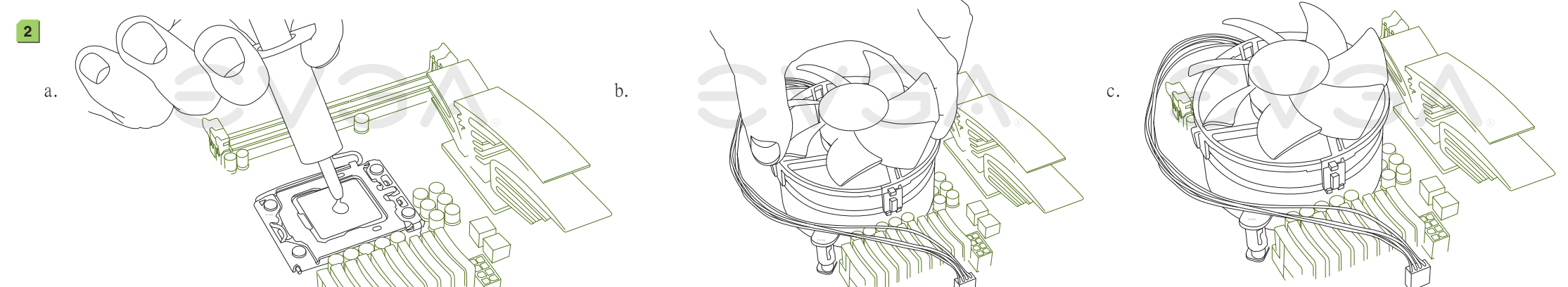

2. Apply a small, pea-sized drop of thermal paste on to the middle of the processor. Install your processor heatsink and fan.

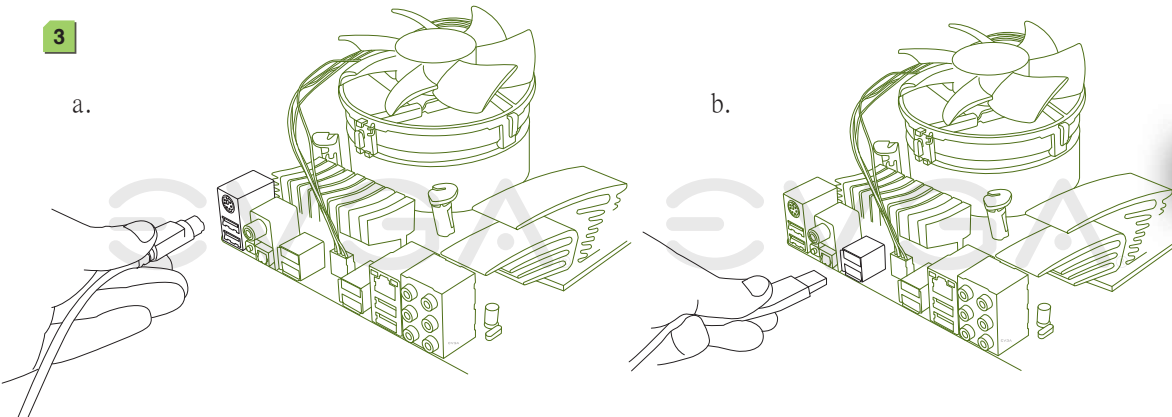

3. Plug in one keyboard into a USB port or PS/2 port.

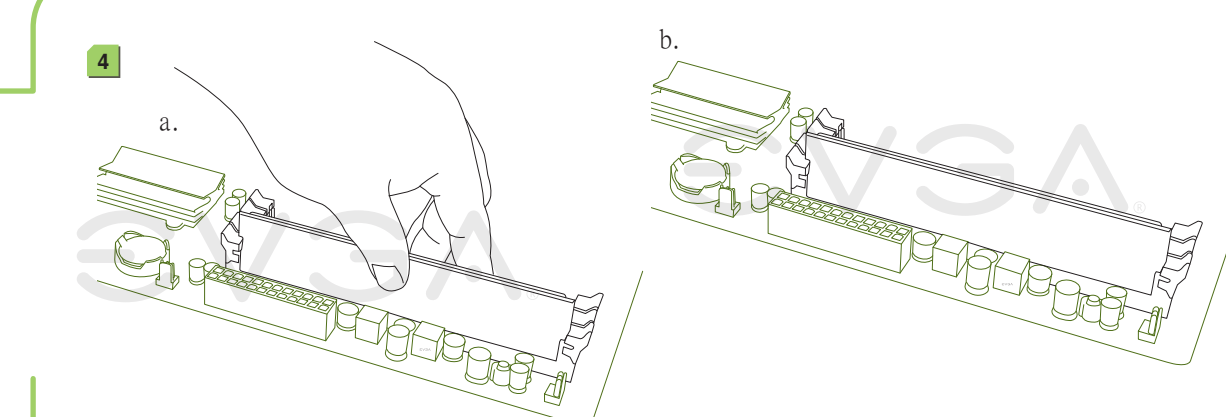
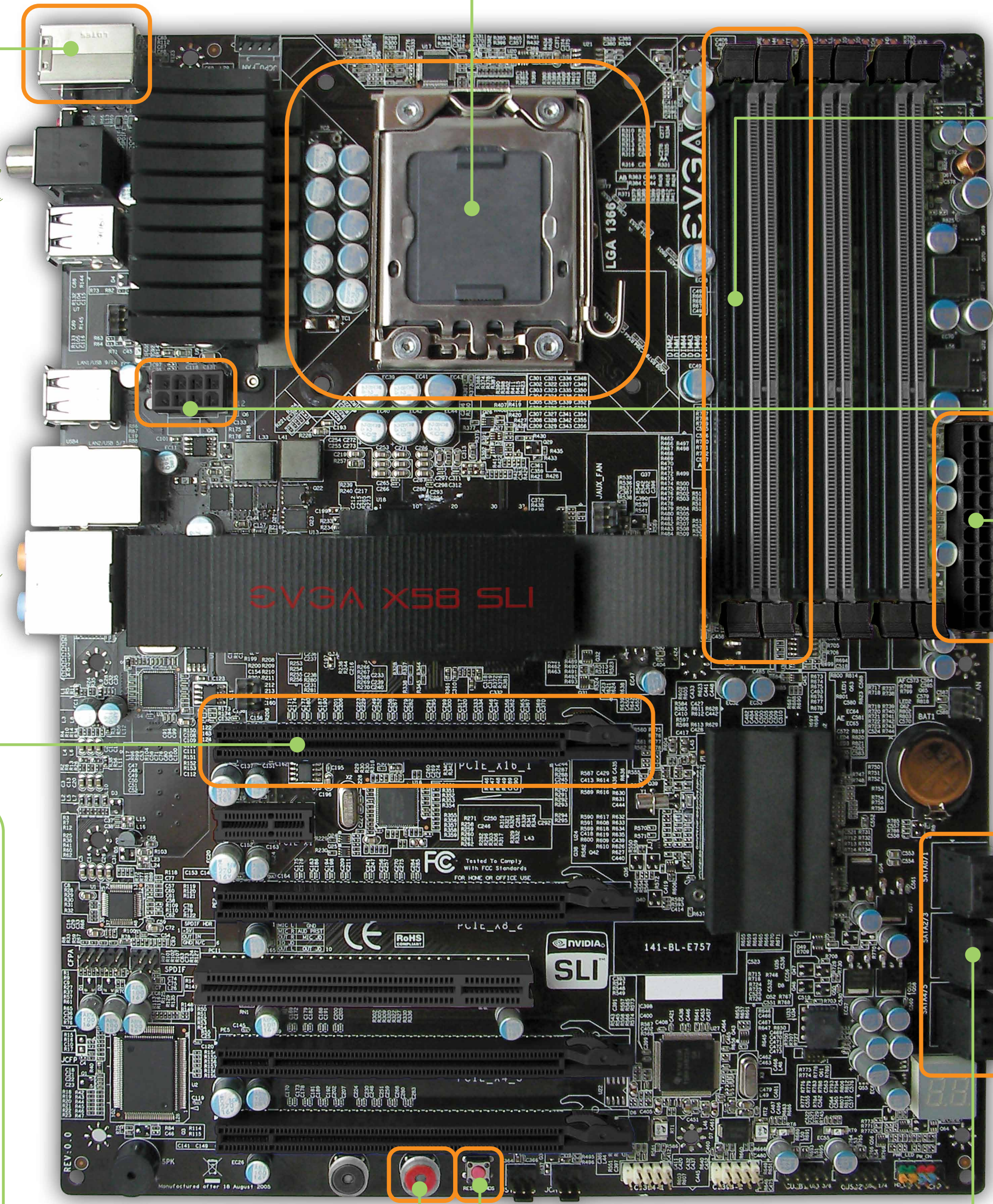

4. Install one stick of system memory (DIMM) into the appropriate DIMM slot (see other side).

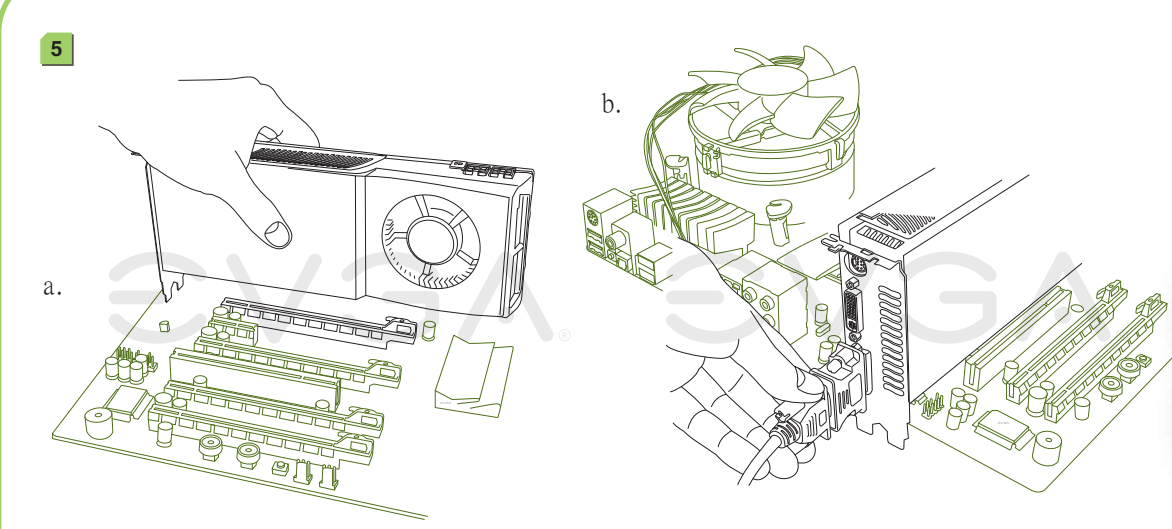

5. Insert your graphics card into either the PCI-E 2.0 slot or the PCI slot. The type of slot depends on the graphic card bus type. Connect a monitor to the output connector of the graphics card.

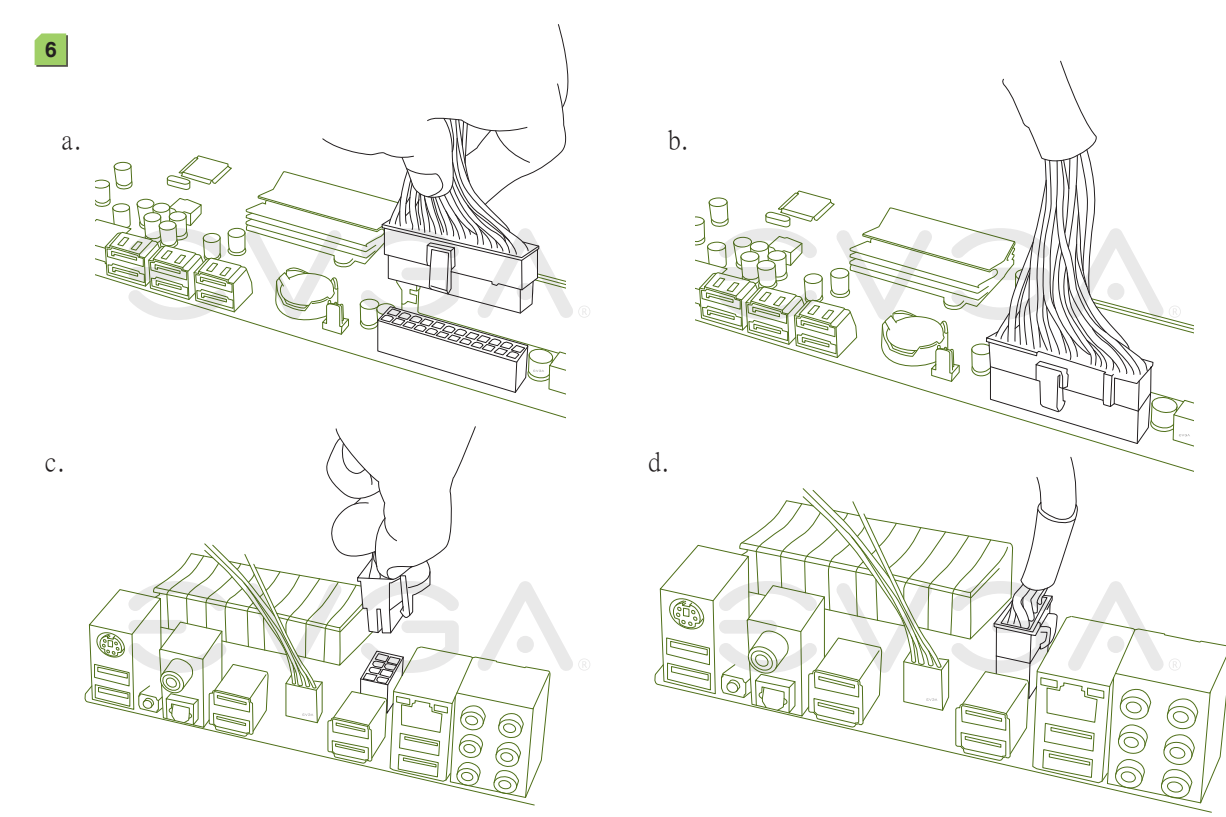

6. Make sure your power supply's power switch is in the OFF position then connect your 24-Pin ATX Power Connector and 8-Pin CPU Power Connector to the motherboard.

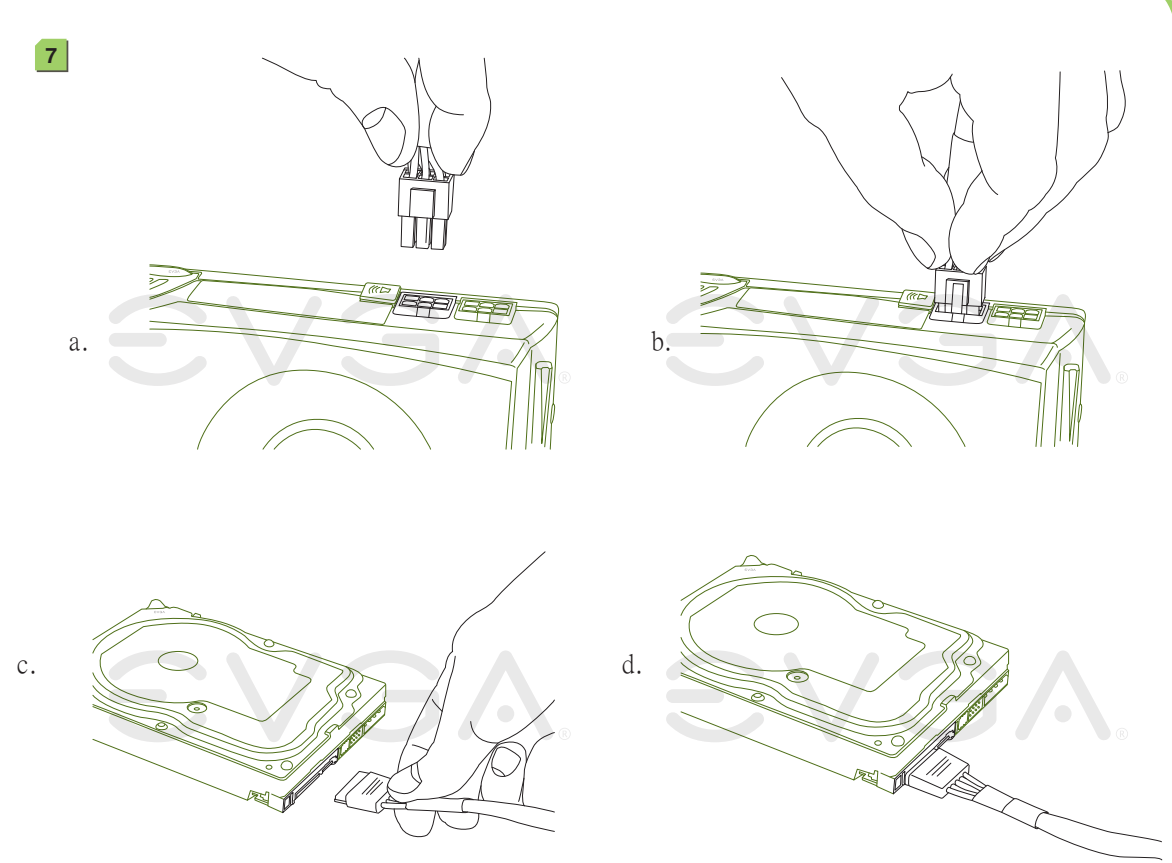

7. Plug in power connectors to both the graphics card and the hard disk drive. Power connector types will vary depending on the hard disk drive and graphic card's power requirements.

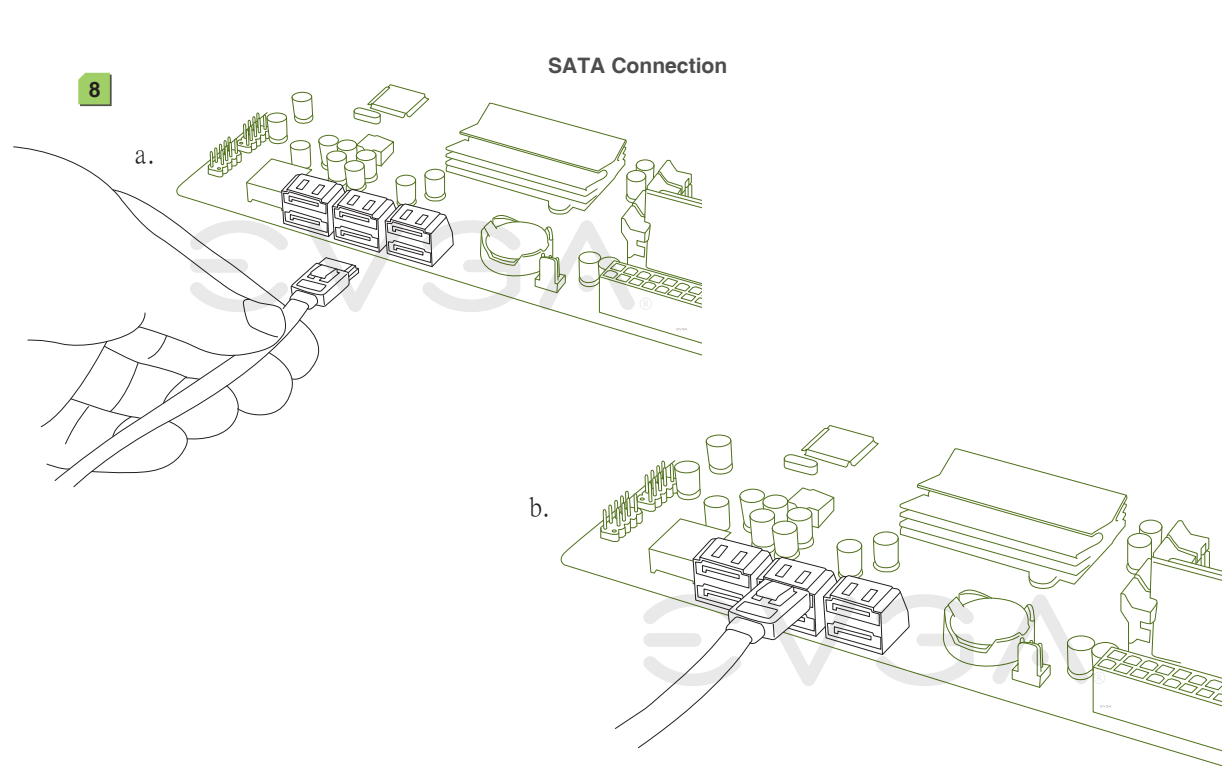

8. Connect one hard drive disk to either one of the SATA Connectors.

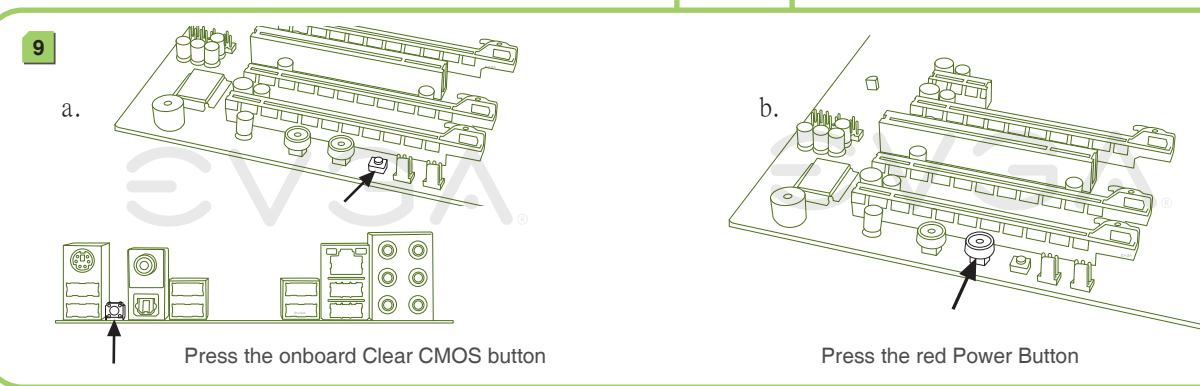

9. Press the onboard Clear CMOS button

Press the red Power Button

On the power supply, flip the power switch to the ON position. LEDs will now be lit on the motherboard. Press the onboard Clear CMOS button once then press the red Power Button to begin powering up the system.

At this final stage, you should now be greeted with the POST screen on your monitor.

EVGA X58 SLI LE VISUAL GUIDE

Please see the manual for more details.

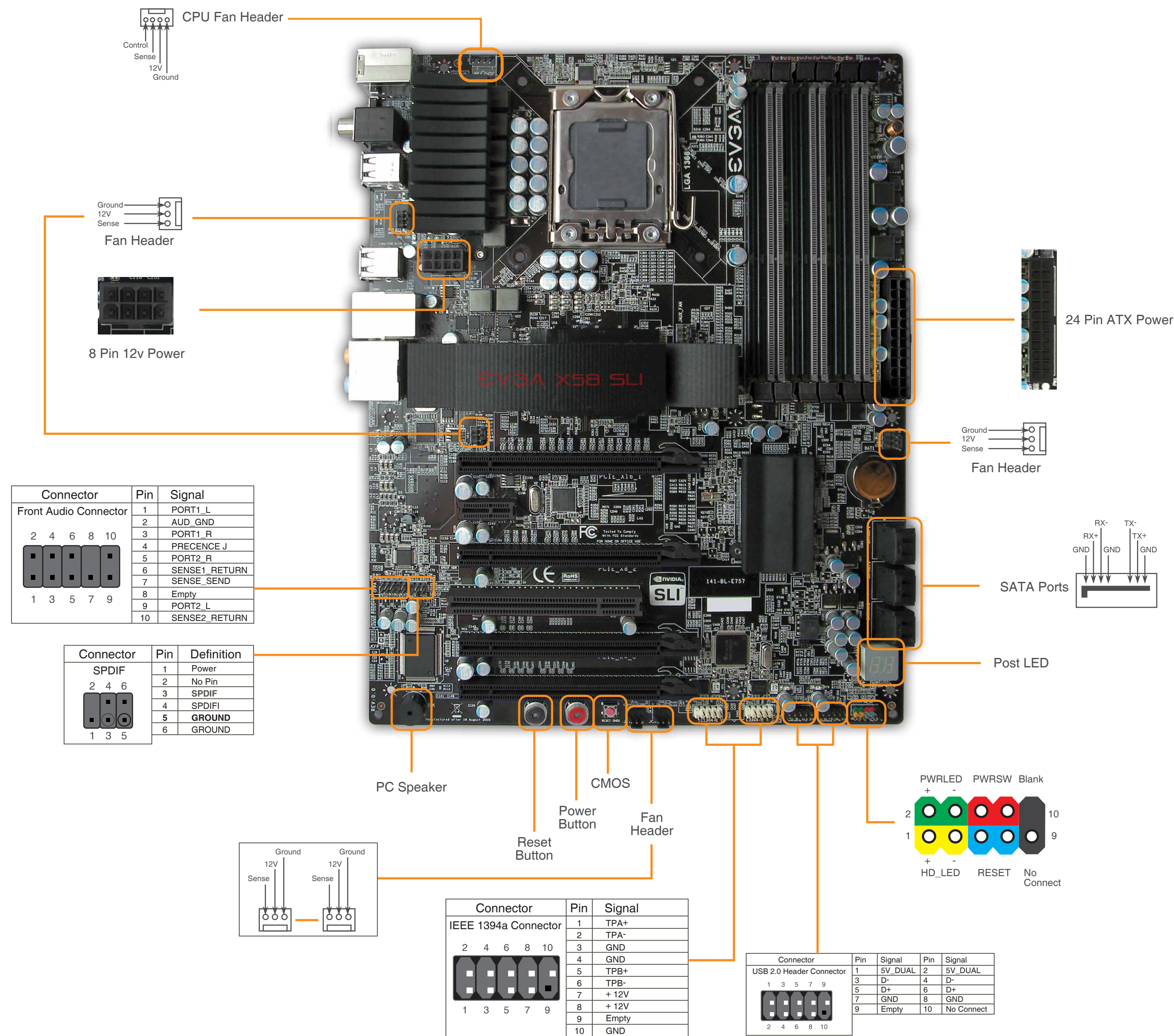

- 1. PS/2 Keyboard Port
- 2. USB 2.0 Ports
- 3. Clear CMOS
- 4. Coaxial SPDIF Output
- 5. Optical SPDIF Output
- 6. LAN Ports (10/100/1000)
- 7. Audio Ports

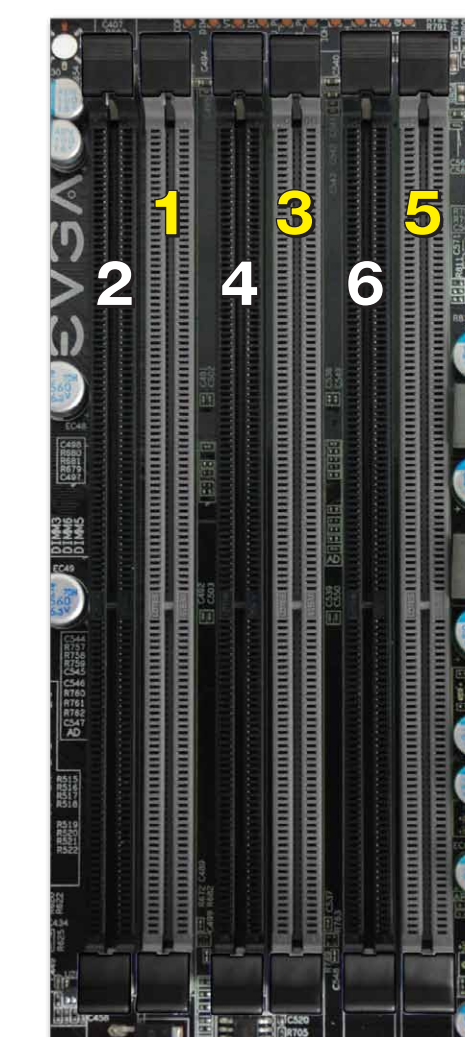

- **One DIMM:** If using 1 DIMM (Single Channel), install into: **DIMM slot 1.**
- **Two or Four DIMMs:** If using 2 DIMMs (Dual Channel), install into: **DIMM slots 1 and 3.** If using 4 DIMMs (Dual Channel), install into: **DIMM slots 2, 1, 4, and 3.**
- **Three DIMMs:** If using 3 DIMMs (Triple Channel), install into: **DIMM slots 1, 3, and 5.**
- **Six DIMMs:** If using more than 4 DIMMs, use: **DIMM slots 2, 1, 4, and 3** then proceed to occupy the following DIMM slots in this order: **5 and 6.**

ATTENTION:
EVGA recommends applying **1.65V or less** when setting the DIMM Voltage. This will support long term stability.

EVGA | Premium Services

Advanced RMA:
Protect yourself and accelerate the RMA process.
www.evga.com/EAR

1+1 Warranty:
Register the purchased product within 30 days to receive 2 year warranty.
www.evga.com/warranty

MODS RIGS:
Show off your rig, post your specs, submit your score, and win big.
www.modsrigs.com

EVGA | Software

E-LEET:
Easily push the boundaries of your hardware with this exclusive tuning utility.
www.evga.com/elet

EVGA | Support

24/7 Support
888-881-EVGA '27/7 North America only
www.evga.com/24-7

Thank you for purchasing an EVGA product. Please remember to register your product at:
www.evga.com/register

For the latest drivers and updates for your product please visit:
www.evga.com/support/drivers

To visit and search our knowledge base and product FAQ please visit:
www.evga.com/FAQ

To visit the EVGA community message boards please visit:
forums.evga.com

For more information about these services as well as our terms and conditions please visit
www.evga.com